

DO NOT SCALE. IF IN DOUBT ASK!

FB180 50mm: 60/30
FB180 60mm: 90/60

FIREFLY® BARRIERS CARRY THEIR REGULAR VERTICAL RATINGS

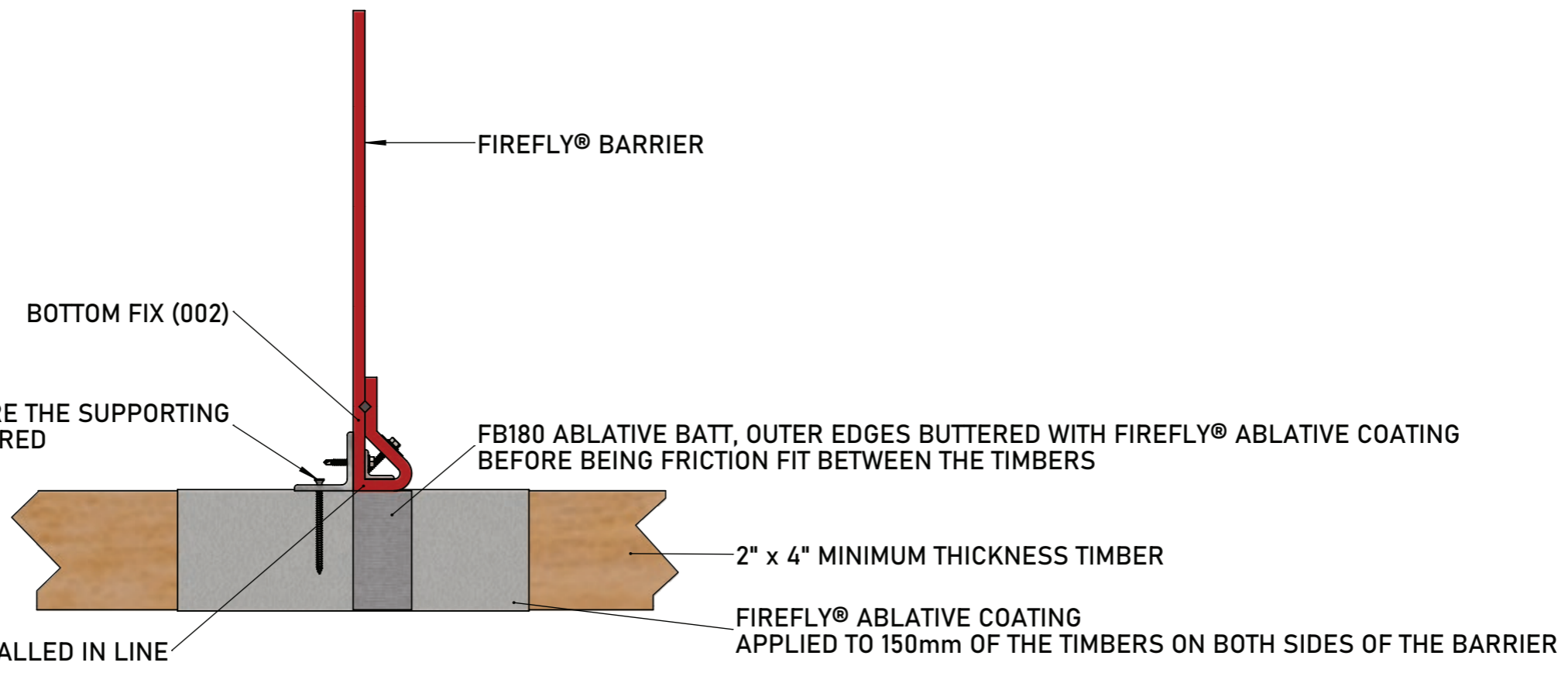
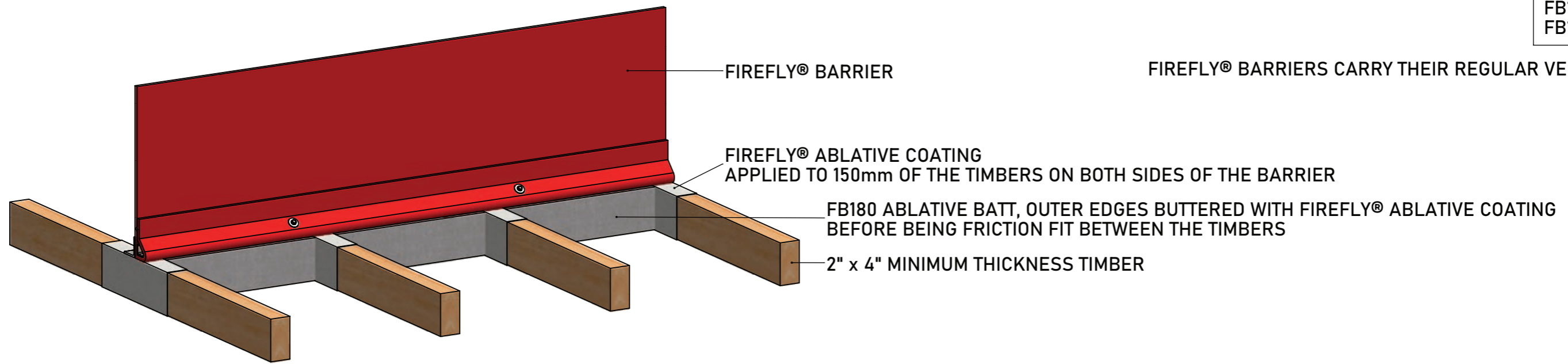

FIREFLY® TIMBER SCREWS SECURE THE SUPPORTING ANGLE TO THE TIMBERS AS REQUIRED

FIREFLY® BARRIER MUST BE INSTALLED IN LINE WITH FB180 ABLATIVE BATTS

FB180 - ABLATIVE BATT BETWEEN JOINTS

TBA PROTECTIVE TECHNOLOGIES LTD
Unit 3, Transpennine Trading Estate,
Gorrells Way Rochdale, OL11 2PX,
United Kingdom
T: +44 (0)1706 758 817
E: Technical@TBAFIREFLY.com
W: WWW.TBAFIREFLY.COM

DESIGNER: JC

APPROVED: KG

DATE: 11/03/2024

SCALE: NTS

DRAWING NO:

B - 005

REVISION: 1

IN SEQUENCE: 1/1

All rights reserved. No parts of this drawing may be used reproduced, altered, stored in a retrieval system or transmitted in any form or by any means without the prior written permission of tba protective technologies ltd. Whilst every effort has been made to comply with the current statutory regulations, it is the user's responsibility to ensure that the final detailing and installation meets the requirements of relevant regulatory authority (often building control). Please check www.tbafirefly.com to ensure that you are using the correct and current version. Copyright © 2023

