

DO NOT SCALE. IF IN DOUBT ASK!

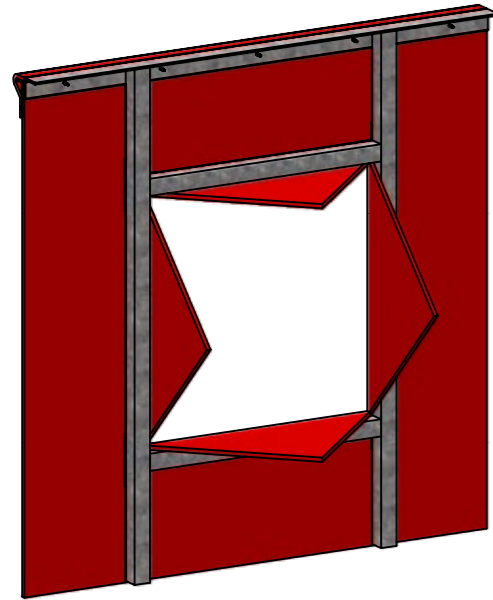

THE FRAMEWORK IS INSTALLED IN THE DESIRED LOCATION (P-401)  
 THE TOP FIX AND VERTICAL BARRIER IS INSTALLED SECOND  
 CUT THE BARRIER AS REQUIRED TO ACCOMMODATE THE PENETRATION  
 THE EXCESS BARRIER FROM THE CUT CAN BE WRAPPED AROUND THE FRAMEWORK  
 THE OVERLAP IS TO BE FIXED WITH FIREFLY® 38mm TEK SCREWS AND WASHERS AS REQUIRED  
 THE BATT EDGES ARE TO BE BUTTERED WITH FIREFLY® FR INTUMESCENT ACRYLIC BEFORE BEING FRICTION FITTED INTO THE FRAMEWORK

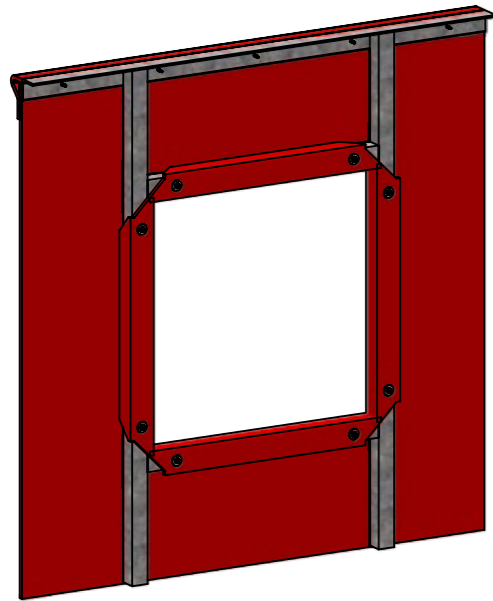

TOP FIX (P-002)

FIREFLY® PHOENIX BARRIER

FIREFLY® FB 180 BATT

BATT EDGES TO BE BUTTERED WITH FIREFLY® INTUMESCENT ACRYLIC BEFORE BEING FRICTION FIT INTO THE FRAMEWORK

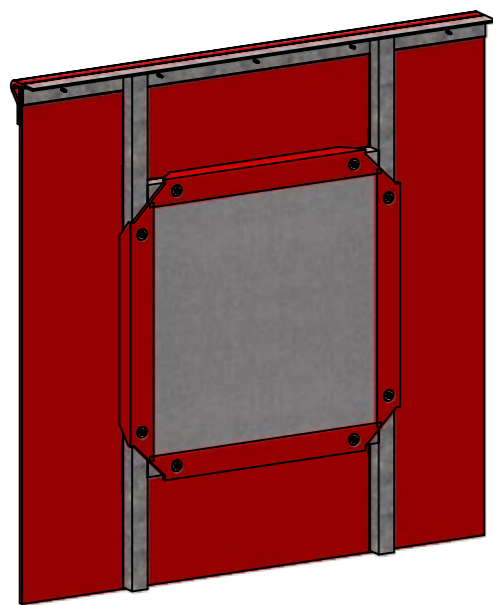
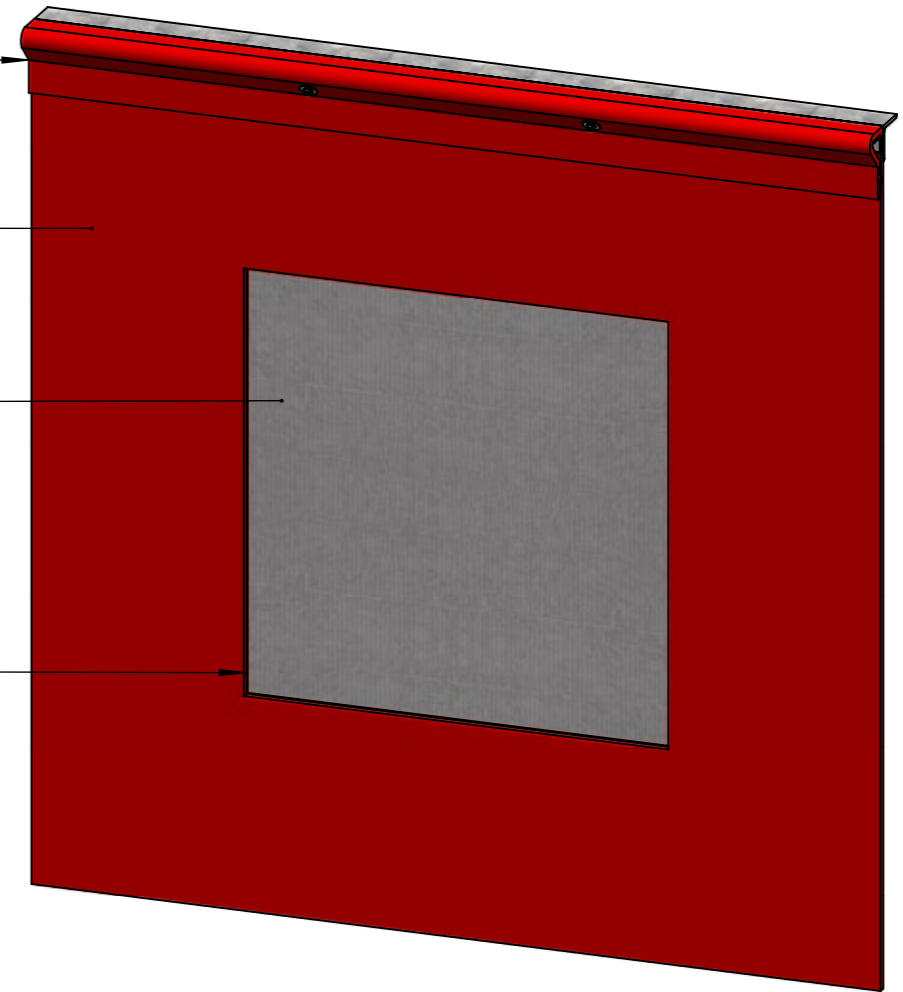

PHOENIX - FB180 BATT INTO FRAMEWORK

TBA PROTECTIVE TECHNOLOGIES LTD  
 Unit 3, Transpennine Trading Estate,  
 Gorrells Way Rochdale, OL11 2PX,  
 United Kingdom  
 T: +44 (0)1706 758 817  
 E: Technical@TBAFIREFLY.COM  
 W: WWW.TBAFIREFLY.COM

DESIGNER: JC

DRAWING NO:

APPROVED: KG

P - 407

DATE: 21/08/2023

REVISION: 4

SCALE: NTS

IN SEQUENCE: 1/1

All rights reserved. No parts of this drawing may be used reproduced, altered, stored in a retrieval system or transmitted in any form or by any means without the prior written permission of tba protective technologies ltd. Whilst every effort has been made to comply with the current statutory regulations, it is the user's responsibility to ensure that the final detailing and installation meets the requirements of relevant regulatory authority (often building control). Please check www.tbafirefly.com to ensure that you are using the correct and current version. Copyright © 2023

