

7 6 5 4 3 2 1

DO NOT SCALE. IF IN DOUBT ASK!

FIREFLY® FB 180 ABLATIVE BATT CUT TO FILL GAP, BUTTERED WITH FIREFLY® ACRYLIC MASTIC AND FRICTION FITTED

PROFILE ROOF

BATT PAINTED WITH FIREFLY® BRUSH GRADE INTUMESCENT MASTIC AFTER FITTING

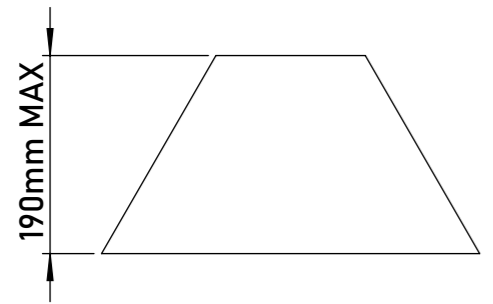
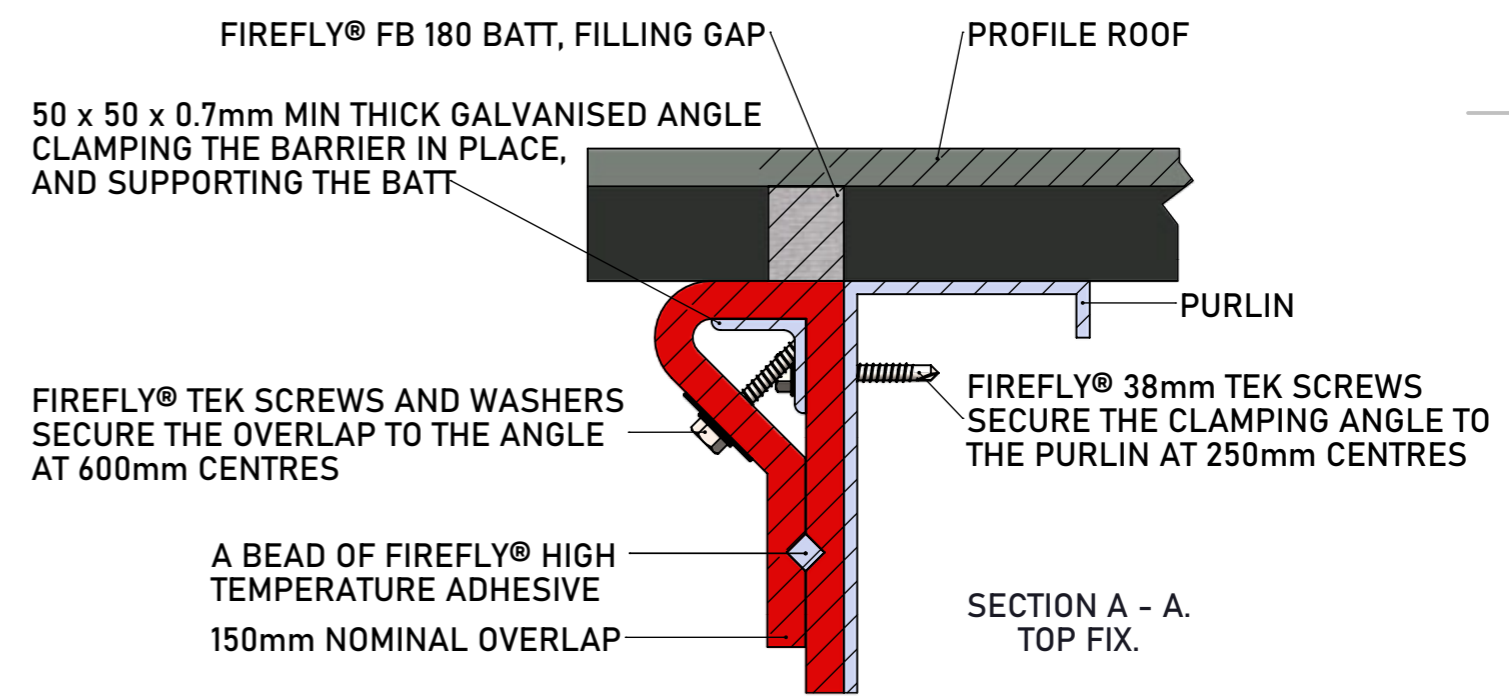
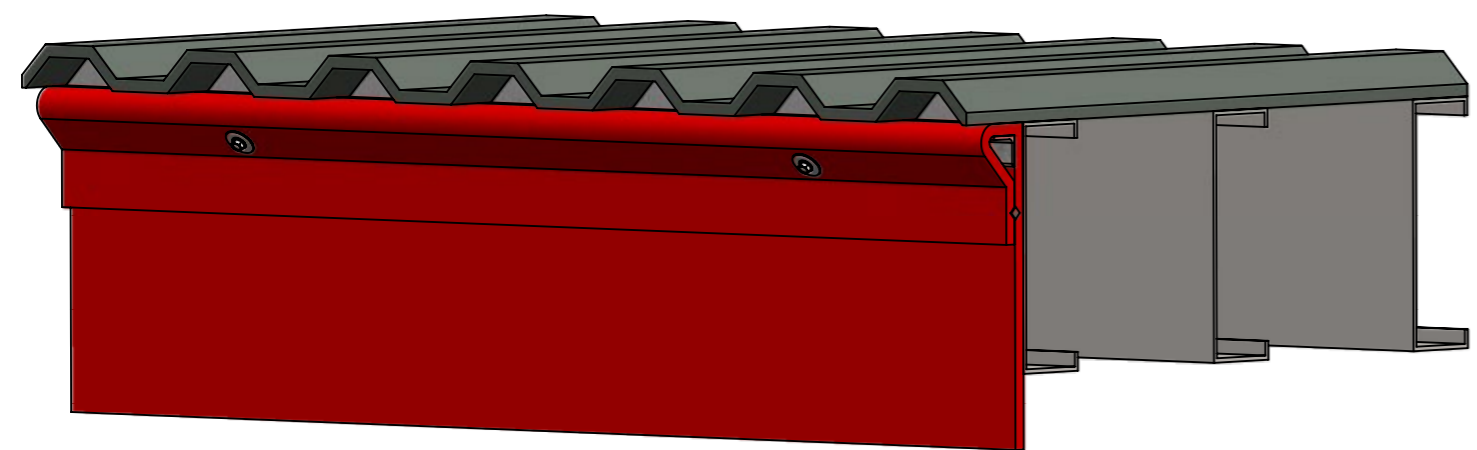
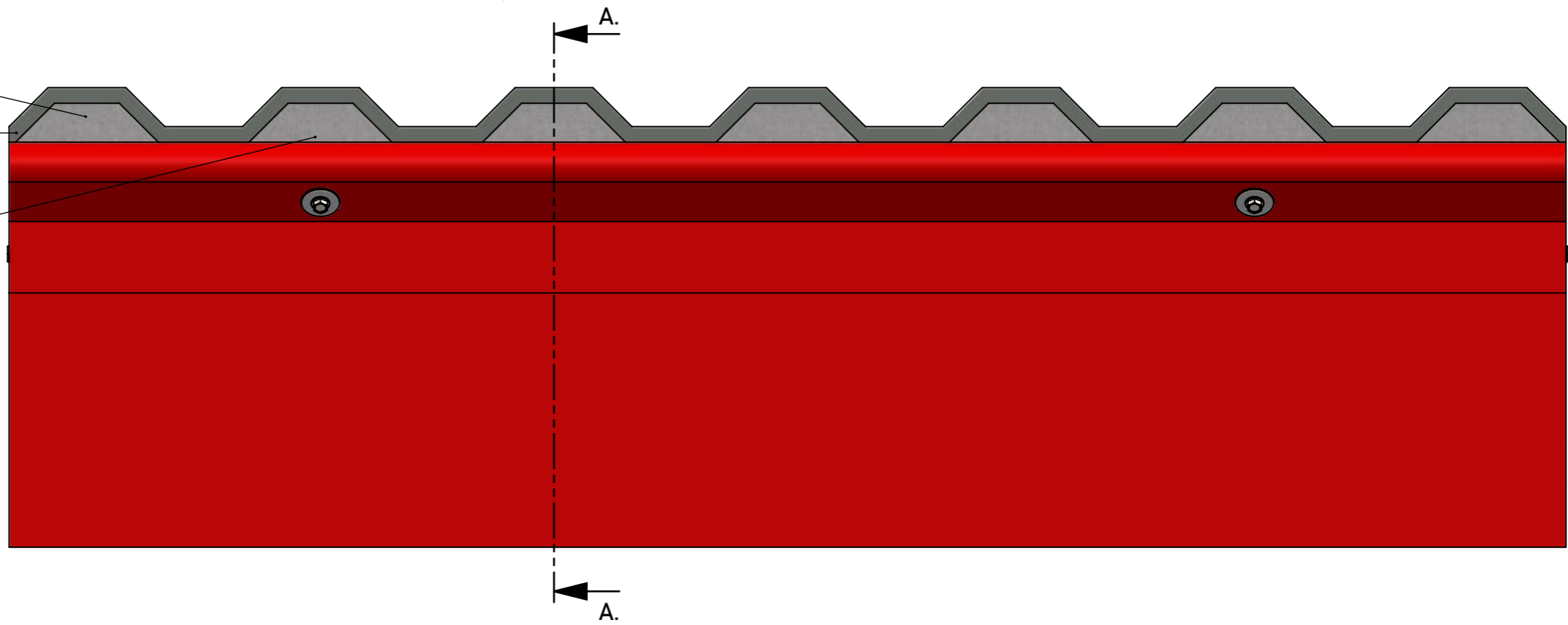

THE MAXIMUM PROFILE DEPTH IS 190mm



All rights reserved. No parts of this drawing may be used reproduced, altered, stored in a retrieval system or transmitted in any form or by any means without the prior written permission of tba protective technologies ltd. Whilst every effort has been made to comply with the current statutory regulations, it is the user's responsibility to ensure that the final detailing and installation meets the requirements of relevant regulatory authority (often building control). Please check www.tbafirefly.com to ensure that you are using the correct and current version. Copyright © 2023

PHOENIX - FIXING TO PROFILE ROOF

TBA PROTECTIVE TECHNOLOGIES LTD Unit 3, Transpennine Trading Estate, Gorrells Way Rochdale, OL11 2PX, United Kingdom T: +44 (0)1706 758 817 E: Technical@TBAFIREFLY.com W: WWW.TBAFIREFLY.COM	DESIGNER: JC	DRAWING NO:
	APPROVED: KG	P - 013
	DATE: 28/08/2023	REVISION: 3
	SCALE: NTS	IN SEQUENCE: 1/1

7 6 5 4 3 2 1