

Fire Resistance Test Report

CONFIDENTIAL

Report: BMT/FEI/F14107 Revision A

Sponsor:

Panel Technologies Ltd
49-61 Jodrell Street
Nuneaton
Warwickshire
CV11 5EG

A fire resistance test performed on a non load bearing 60 minute ceiling membrane fitted with a loft hatch
Test conducted to BS EN 1364-2: 1999 to the temperature and pressure conditions outlined in BS EN 1363-1: 2012

Test date: 11th September 2014



Page 1 of 15

Opinions and interpretations expressed herein are outside the scope of UKAS accreditation. This document is confidential and remains the property of Warringtonfire Testing and Certification Ltd.. The legal validity of this report can only be claimed on the presentation of the complete report.



Revision A – April 2022

This report is a revision to that issued as BMT/FEI/F14107 and dated 16/11/15. The details of the test report of BMT/FEI/F14064 are held on file by Warringtonfire. The original report and any previous revisions are replaced by this revised report BMT/FEI/F14107 Revision A.

Amendments made:

- Figure 2, Page 18 – Frame height amended from 55mm to 59mm.
- Section 4, Page 6 – Board details amended from “15mm thick plasterboard core” to “12.5mm Siniat/GTEC Megadeco core”.
- Rebranded document to Warringtonfire.

The legal validity of this report can only be claimed on presentation of the complete report.

Contents

		Page No
1	Introduction	4
2	Specimen verification	4
3	Description of the ceiling membrane construction.....	6
4	Description of access hatch	6
5	Test conditions.....	9
5.1	Ambient temperature	9
5.2	Pressure readings	9
5.3	Furnace temperature	9
5.4	Unexposed face thermocouple positions	10
6	Observations	11
7	Expression of results	12
8	Limitations	13
9	Field of direct application of test results	14
10	Photographs	15
	Appendix 1 - Client drawing and figures 1 and 2.....	18
	Appendix 2 - raw test data (2 pages)	

The legal validity of this report can only be claimed on presentation of the complete report.

1 Introduction

A loft access hatch was installed into ceiling membrane fixed within a refractory lined steel restraint frame above a 1.5m x 1.5m furnace.

2 Specimen verification

The steel loft hatch was manufactured and supplied for test by the client and delivered during September 2014.

Warringtonfire assembled and fitted a section of British Gypsum (BG) CasoLine MF5 ceiling membrane into a refractory lined steel restraint frame. The ceiling included a 605mm x 605mm aperture, into which Warringtonfire installed the loft access hatch.

Unexposed face prior to testing



The legal validity of this report can only be claimed on presentation of the complete report.

Exposed face prior to testing



The legal validity of this report can only be claimed on presentation of the complete report.

3 Description of the ceiling membrane construction - Reference British Gypsum CasoLine MF 60 minute system ref. C106003

The 1500mm x 1500mm ceiling construction comprised BG Gypframe M6F Primary Support Channel around the ring beam and BG Gypframe MF5 Ceiling Section fitted within the MF6 Primary Support Channel profile at 450mm centres. 2No.sections of BG Gypframe MF7 Primary Support Channel were fitted 1200mm apart, at 90° to the MF5 ceiling section, extending to the MF6 Support channel around the ceiling section. The ceiling system was clad with 2No. layers of 12.5mm thick BG Gyproc FireLine board, the first layer fixed with 32mm long Drywall screws and the second layer with 42mm long Drywall screws, all fitted at maximum 230mm centres.

No insulation was fitted to the upper side of the ceiling membrane.

The loft access hatch aperture was unlined. The loft access hatch frame was sealed to the soffit of the ceiling with Mann McGowan Acrylic mastic, applied prior to fixing in the ceiling aperture.

No suspension fixings were used due to the 1500mm x 1500mm size of the test specimen ceiling section, which was supported on all four sides.

4 Description of access hatch (refers to client drawings of appendix 1)

Access hatch

The hatch panel (Plasterboard Faced Flipfix) measured 588mm long x 588mm wide x 59mm thick overall. The hatch panel frame comprised powder coated 0.9mm thick perforated profiled Zintec steel enclosing a 12.5mm Sinia/GTEC Megadeco core. The frame comprised 0.9mm thick powder coated perforated Zintec steel 600mm long x 600mm wide x 59mm high including a 25mm wide integral architrave. The frame was fixed into the aperture with 4 No. 'flip clip' adjustable fixings. 2 No fixings were present on 2 edges, 130mm from corners on adjacent sides.

The loft access hatch was hinged on a rapid fit hinge with 2 No. pivot points enclosed within the reinforcement channel, with an engaged budget type latch centrally fitted on the opposite edge, and hung opening in towards the furnace.

The hatch panel comprised a tray profile 15.5mm thick, welded at the corners.



Hardware at top right hand corner of unexposed face.

The legal validity of this report can only be claimed on presentation of the complete report.



Budget lock key hole on exposed face

The legal validity of this report can only be claimed on presentation of the complete report.

5 Test conditions

5.1 Ambient temperature

The ambient temperature of the test area at commencement of test was 18°C. The ambient temperature for the duration of the test has been recorded in Appendix 2.

5.2 Pressure readings

After the first 5 minutes of the test, the furnace pressure was maintained at 13.2 ± 5 Pa and after 10 minutes was maintained at 13.2 ± 3 Pa, equating to 20 Pa at the underside of the ceiling soffit. The pressure readings have been tabulated in Appendix 2.

5.3 Furnace temperature

The furnace was controlled to follow the temperature/time relationship specified in BS EN 1363: Part 1: 2012 Section 5.1.1 as closely as possible, using the average of five plate thermometers suitably distributed within the furnace. The temperatures recorded have been tabulated in Appendix 2 and are shown graphically overleaf:

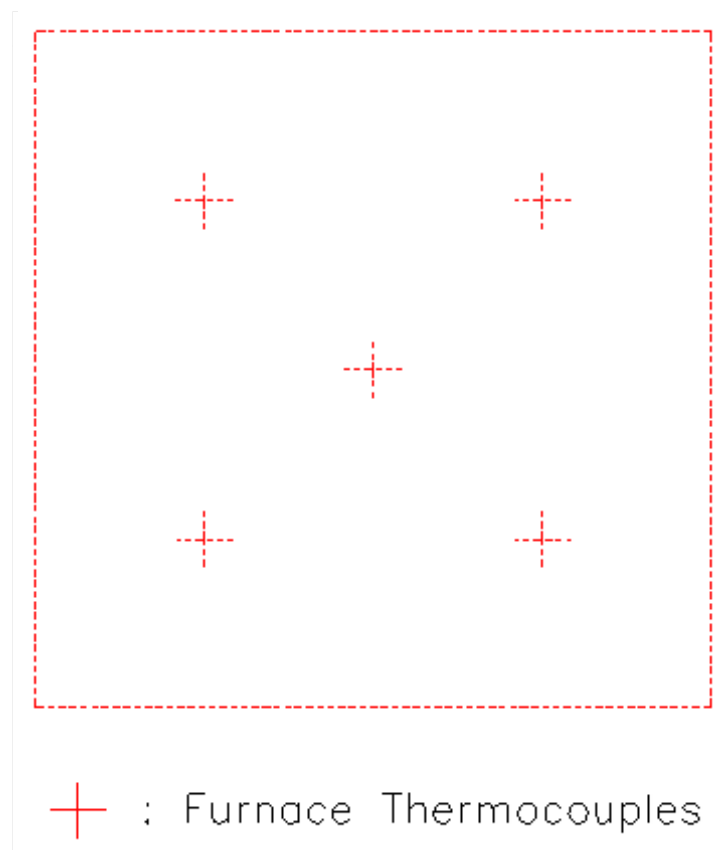

The legal validity of this report can only be claimed on presentation of the complete report.

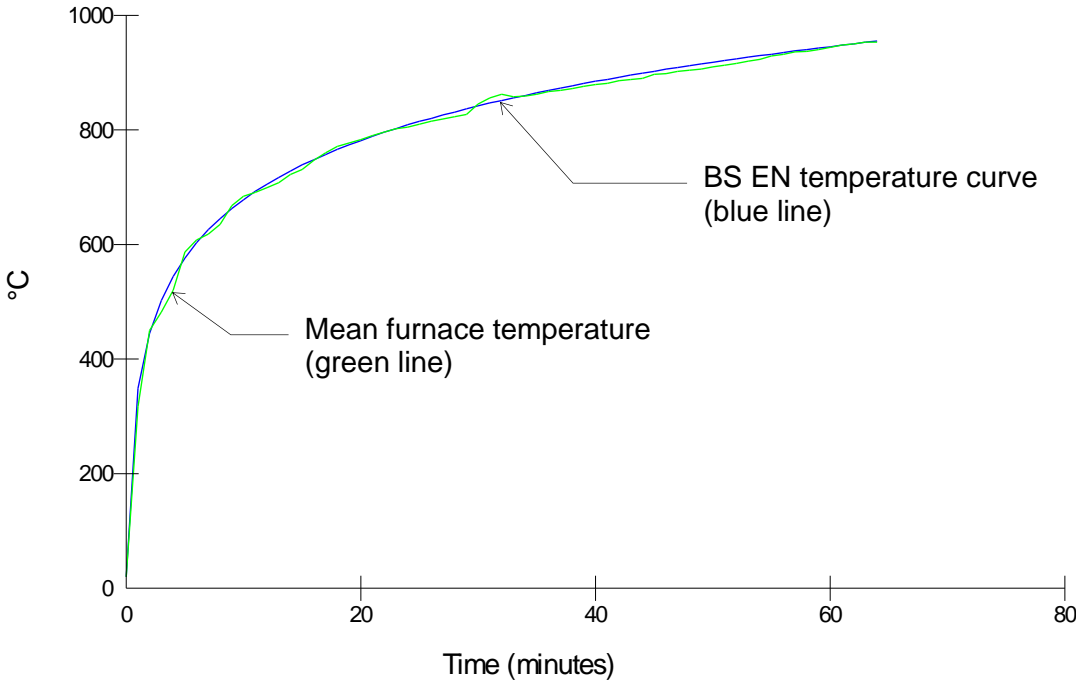

5.4 Unexposed face thermocouple positions

The specimen was declared to be uninsulated, so no thermocouples were fitted at the sponsor's request

The legal validity of this report can only be claimed on presentation of the complete report.

6 Observations

All comments relate to the unexposed face unless otherwise specified.

Time (minutes)

00.00	Test started.
01.00	There is smoke issuing from the perimeter of the frame.
03.50	There is discolouration at the inside edge of the frame.
04.10	There is an increase in smoke issuing from the perimeter of the frame.
04.40	There is discolouration at the edges of the leaf.
05.40	The paint on the hanging edge of the frame is burning away.
08.50	There is discolouration to the box section at the closing edge.
15.20	The paint at the closing edge is burning away from both the frame and the leaf.
18.00	The leaf face is to rippling.
19.20	The top closing corner of the leaf has deflected into the furnace by approximately 5-7mm.
25.10	There is further discolouration to the edge of the leaf.
32.30	The top closing corner of the leaf has deflected into the furnace by approximately 7-10mm.
43.30	There is discoloration over the entire face of the leaf.
52.00	Exposed face, the first layer of the plasterboard is starting to fall away from the ceiling membrane.
55.00	The top closing corner of the leaf has deflected into the furnace by approximately 10-15mm.
56.00	There is discolouration to the ceiling at the perimeter of the frame.
63.00	The specimen is starting to fall through the ceiling at the hanging edge.
64.00	Test terminated.

The legal validity of this report can only be claimed on presentation of the complete report.

7 Expression of results

Integrity			Insulation
Continuous flaming	Gap gauge	Cotton pad	Maximum
64 (sixty four) minutes*	64 (sixty four) minutes*	64 (sixty four) minutes*	0 (zero) minutes**

* No failure had occurred at termination of the test at 64 minutes

** The specimen has not been evaluated for insulation

8 Limitations

This report details the method of construction, the test conditions and the results obtained when the specific element of construction described herein was tested following the procedure outline in EN 1363-1, and where appropriate EN 1363-2. Any significant deviation with respect to size, construction details, loads, stresses, edge or end conditions other than those allowed under the field of direct application in the relevant test method is not covered by this report.

The results only relate to the behaviour of the element of construction under the particular conditions of test; they are not intended to be the sole criteria for assessing the potential fire performance of the element in use nor do they reflect the actual behaviour in fires.

The specification and interpretation of fire test methods are the subject of ongoing development and refinement. Changes in associated legislation may also occur. For these reasons it is recommended that the relevance of test reports over 5 years old should be considered by the user. Warringtonfire will be able to offer, on behalf of the legal owner, a review of the procedures adopted for a particular test to ensure that they are consistent with current practices, and if required may endorse the test report.

Because of the nature of fire resistance testing and the consequent difficulty in quantifying the uncertainty of measurement of fire resistance, it is not possible to provide a stated degree of accuracy of the result.

In accordance with clause 6.1.1 of BS EN 1364-2 1999, this specimen was deemed to be tested as full size and therefore meets the requirements of the standard. Further testing would be necessary for ceiling sections larger than that tested.

	Written and checked by:	Authorised by:
Signature:		
Name:	Adriano Montanino	Victor Kearley
Title:	Technical Officer	Technical Author
Date of issue:	28/04/2022	28/04/2022

The legal validity of this report can only be claimed on presentation of the complete report.

9 Field of direct application of test results

The results of the test are directly applicable to similar constructions where one or more of the changes listed in BS EN 1364-2: 1999, Clause 13, are made and the construction continues to comply with that appropriate design code for its stiffness and stability. Other changes are not permitted by the document. A copy of the field of direct application is available from Warringtonfire upon request.

10 Photographs

Unexposed face at start of test



After 10 minutes

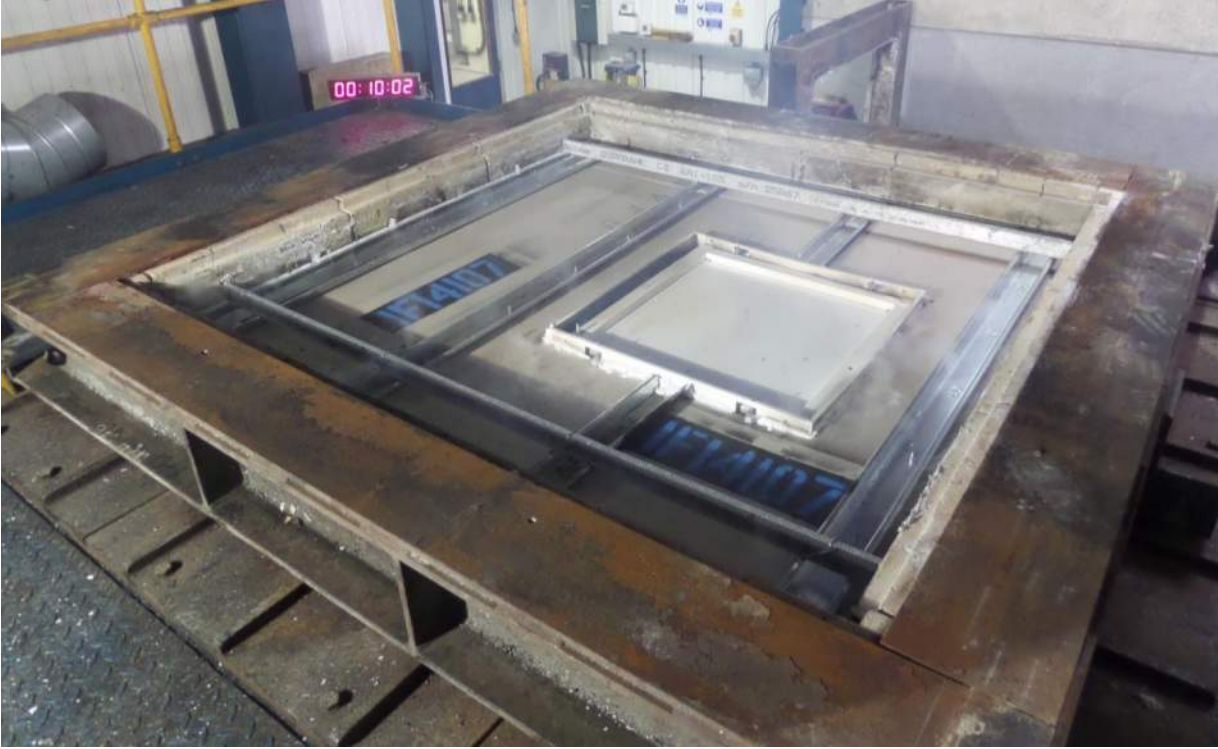

The legal validity of this report can only be claimed on presentation of the complete report.

At 30 minutes



At 45 minutes



The legal validity of this report can only be claimed on presentation of the complete report.

After 60 minutes



The legal validity of this report can only be claimed on presentation of the complete report.

Appendix 1 - Client drawing and figures 1 and 2

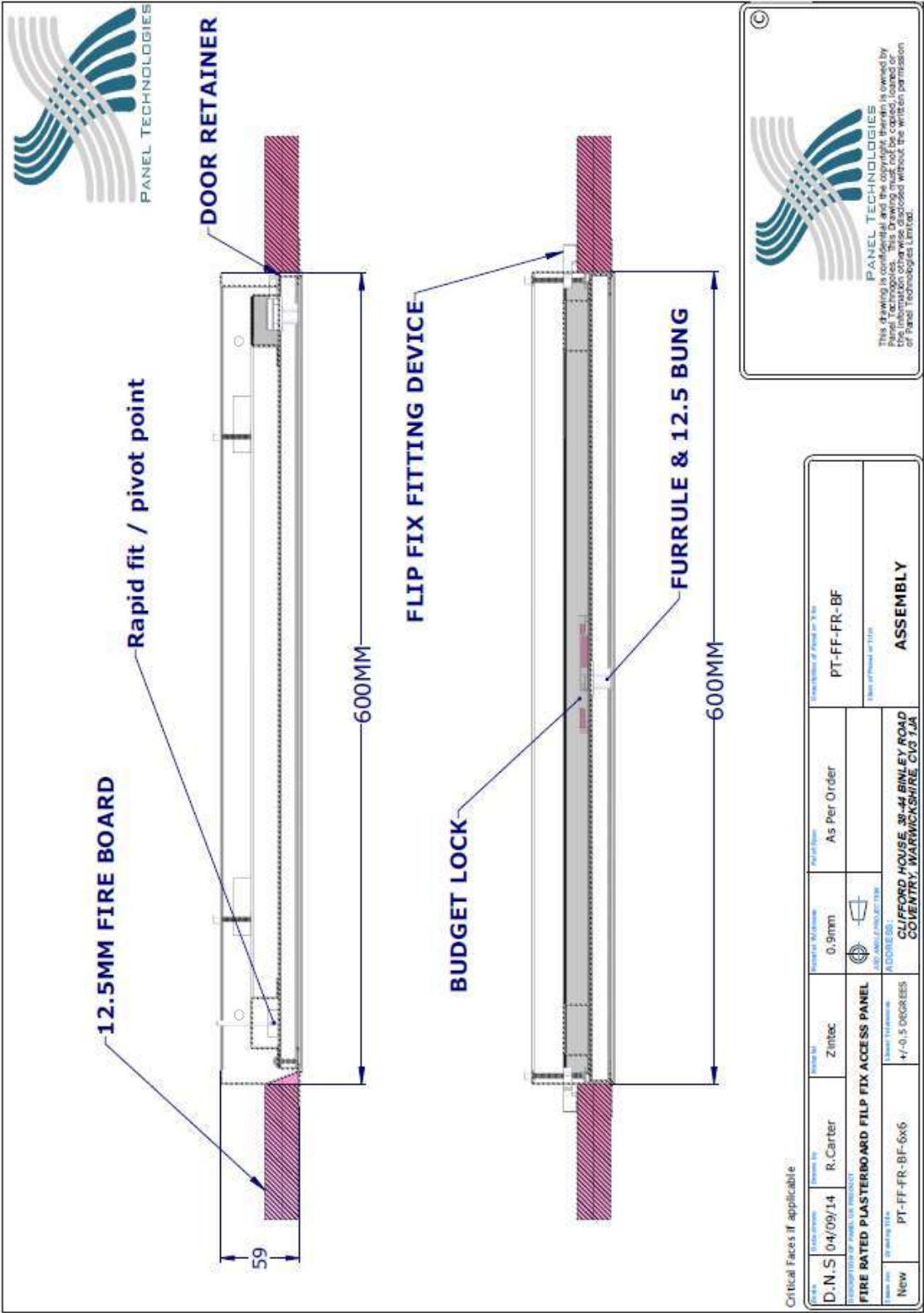

The legal validity of this report can only be claimed on presentation of the complete report.

Front of furnace

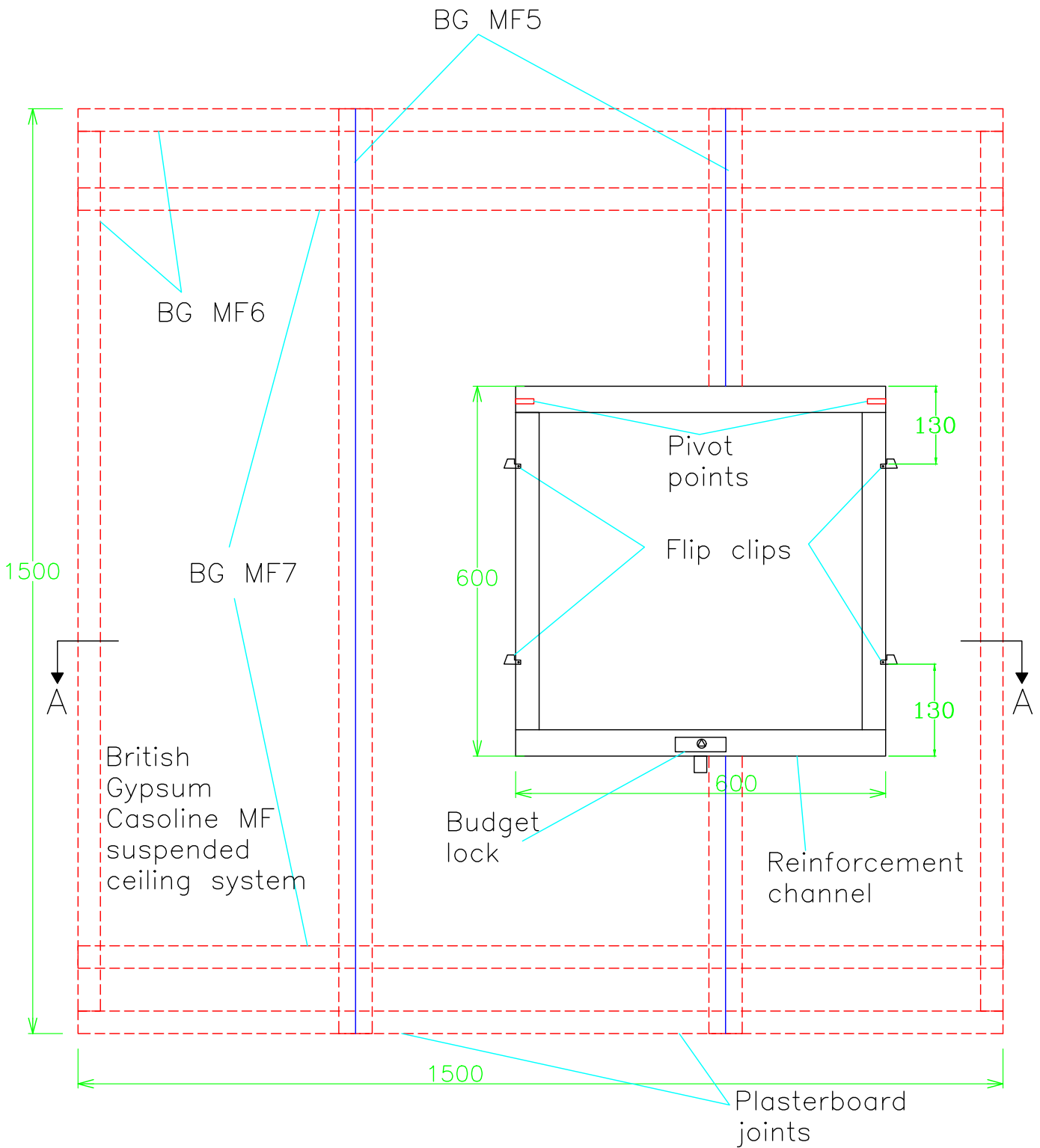

Chiltern House, Stocking Lane, Hughenden Valley
High Wycombe, Buckinghamshire, HP14 4ND, UK.
Tel: +44 (0)1494 569800 Fax: +44 (0)1494 564895

Title Unexposed face plan view
and hardware positions
(All dimensions in mm)

Date Drawn
15/09/14

Drawn By
ARD

Scale
NTS

Project No.
BMT/FEI/F14107 RevA

Appendix 1

Section A – A

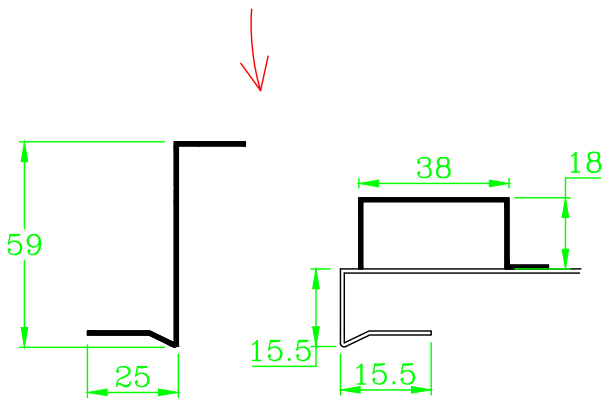
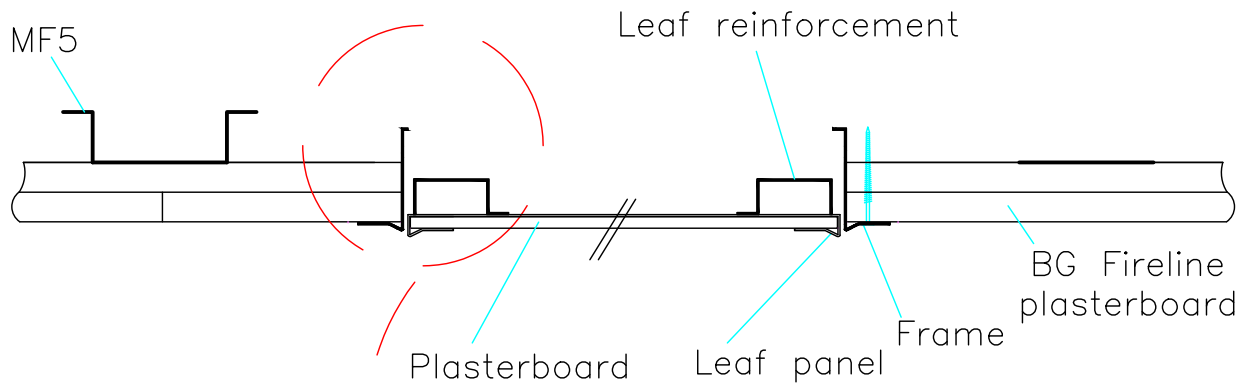

Chiltern House, Stocking Lane, Hughenden Valley
 High Wycombe, Buckinghamshire, HP14 4ND, UK.
 Tel: +44 (0)1494 569800 Fax: +44 (0)1494 564895

Title

Cross section of access panel
 (All measurements in mm)

Date Drawn

15/09/14

Drawn By

ARD

Scale

NTS

Project No.

BMT/FEI/F14107 RevA

Appendix 1

Appendix 2 - raw test data (2 pages)

Furnace thermocouples

Time	Chan 0	Chan 1	Chan 2	Chan 3	Chan 4	Chan 5	Ambient
min	Pa	°C	°C	°C	°C	°C	°C
0	0	29	30	30	31	31	18
1	11.2	256	274	398	299	361	18
2	13.5	411	429	505	435	470	18
3	13.7	459	463	532	471	489	18
4	13.1	497	498	567	514	524	18
5	11.6	546	564	632	592	601	18
6	13.8	568	579	657	620	619	18
7	14	579	590	667	630	627	18
8	14.2	593	605	685	650	646	18
9	14.4	634	624	721	687	675	18
10	13.7	650	641	731	707	692	18
11	14.1	661	650	742	710	696	18
12	12.8	669	660	749	717	703	18
13	12.8	677	670	756	729	712	18
14	13.5	691	698	761	738	724	18
15	14.2	698	709	772	748	731	18
16	13.2	716	726	787	761	748	18
17	13.6	728	739	798	776	763	18
18	13.3	740	750	806	786	773	18
19	12.8	745	755	814	793	779	18
20	14.4	753	763	820	796	786	18
21	13.8	760	769	824	806	793	18
Time	Chan	Chan	Chan	Chan	Chan	Chan	Ambient

	0	1	2	3	4	5	
min	Pa	°C	°C	°C	°C	°C	°C
22	12.3	767	777	830	810	796	18
23	13.4	772	783	835	817	803	18
24	13.3	778	787	838	821	805	18
25	13.4	784	792	843	825	810	18
26	11.5	789	799	846	827	815	18
27	14.1	793	801	851	832	822	18
28	13	799	807	854	835	822	18
29	14.3	803	808	856	841	828	18
30	13.3	821	828	877	857	843	18
31	14	833	840	889	865	853	18
32	12.7	840	847	890	874	861	18
33	13.1	834	840	887	870	859	18
34	14.1	837	842	888	871	858	18
35	14.1	841	845	889	873	862	18
36	12.6	846	852	895	880	866	18
37	13.9	849	856	899	878	866	18
38	12.2	853	857	902	881	869	18
39	14.2	855	861	904	887	874	18
40	12.9	860	864	906	888	881	18
41	12.9	862	866	907	892	881	18
42	13	866	871	911	897	885	18
43	13.8	869	874	915	898	888	18

Time	Chan 0	Chan 1	Chan 2	Chan 3	Chan 4	Chan 5	Ambient
min	Pa	°C	°C	°C	°C	°C	°C
44	13.7	873	875	916	901	889	18
45	13.4	877	883	920	908	897	18
46	13.3	879	882	921	910	899	18
47	14.1	882	886	925	915	904	18
48	13.7	887	889	926	916	903	18
49	12.5	889	892	930	917	906	18
50	14.2	892	897	934	920	909	18
51	13.7	894	898	934	926	915	18
52	12.1	898	900	938	928	919	18
53	14.2	902	908	944	930	919	18
54	12.6	905	903	947	934	926	18
55	13.4	910	913	952	938	932	19
56	13	913	918	955	940	934	18
57	12.5	918	920	959	946	939	18
58	12.3	921	922	961	945	940	18
59	12.8	924	926	963	949	942	18
60	12.2	927	930	966	953	946	18
61	13	931	932	968	958	951	18
62	13	933	933	971	961	954	19
63	13	936	936	974	964	957	19
64	10.6	936	930	973	963	964	19