

Sponsor:

ROCKWOOL Limited
Pencoed
Bridgend
CF35 6NY
United Kingdom
www.rockwool.com



Solutions

Prepared by:

UL International (UK) Ltd

Approved body No.:

0843

Product Name:

FirePro® AIS Fire Resistant Sealant

Project No.:

4791353094.1

Report No.:

4791353094.1-01

Issue number:

01

Date of Issue:

25.06.2025

Copyright © 2025 UL LLC.

UL International (UK) Ltd.
220, Cygnet Court, Centre Park, Warrington. WA1 1PP

This classification report consists of 28 pages and may only be used or reproduced in its entirety.

TABLE OF CONTENTS

1. Introduction	3
2. Details of classification product	3
3. Test reports in support of classification.....	3
4. Classification and field of application	12
5. Limitations.....	24
6. Signatories.....	24
Annex A.....	25

1. Introduction

This classification report defines the classification assigned to the product FirePro® AIS Fire Resistance Sealant, in accordance with the procedures given in EN 13501-2: 2023.

2. Details of classification product

2.1 General

The product FirePro® AIS Fire Resistance Sealant is a one-part water based acrylic sealant that is designed for use in the installation of FirePro® CB50, sealing linear joints and some individual service penetrations passing through various substrates.

2.2 Product description

The element, FirePro® AIS Fire Resistance Sealant, is fully described in the test reports provided in support of Classification, detailed in clause 3.1.

3. Test reports in support of classification

3.1 Summary of test reports

Name of laboratory	Name of sponsor	Test reference	Test date	Test method
FPA – UKAS Accreditation no. 10536	Rockwool Limited	FPA 104787 r0	13/02/2024	EN 1366-4: 2021
		FPA 104950 r0	27/02/2024	
		FPA 105764 r0	20/02/2024	
		FPA 106130 r0	08/05/2024	
Warringtonfire Testing and Certification Limited – UKAS Accreditation no. 0249	Rockwool Limited	551825A/R Iss1	28/04/2025	EN 1366-4: 2021

3.2 Results

Summary of report No.: FPA 104787 r0

A range of twelve rockwool FIREPRO AIS Fire Resistance Sealant linear joint seals, mounted into apertures formed within a 100 mm thick EI 90 standard flexible wall construction. All joints were sealed on each face in a symmetrical configuration. The joint configurations followed the rules given in National Annex NA of the standard.

Vertically orientated seals within a flexible wall

Specimen	Seal width	Seal depth	Substrate	Backing material	Integrity (minutes)		Insulation (minutes)
					Cotton Pad	Sustained Flaming	
A1	30mm	15mm	Pb - Pb	PU foam backing	132*	132*	132*
B1	50mm	25mm	Pb - Pb	PU foam backing	132*	132*	132*
C1	30mm	15mm	Pb - Sw	PU foam backing	132*	132*	132*
D1	50mm	25mm	Pb - Sw	PU foam backing	132*	132*	132*
E1	30mm	15mm	Pb - Hw	PU foam backing	128	130	128
F1	50mm	25mm	Pb - Hw	PU foam backing	132*	132*	132*

Pb - Plasterboard

Sw - Softwood

Hw - Hardwood

*Test was discontinued after a period of 132 minutes without a failure being observed.

Horizontally orientated seals within a flexible wall

Specimen	Seal width	Seal depth	Substrate	Backing material	Integrity (minutes)		Insulation (minutes)
					Cotton Pad	Sustained Flaming	
A2	30mm	15mm	Pb - Pb	PE foam backing	132*	132*	127
B2	50mm	25mm	Pb - Pb	PE foam backing	132*	132*	132*
C2	30mm	15mm	Pb - Sw	PE foam backing	132*	132*	132*
D2	50mm	25mm	Pb - Sw	PE foam backing	132*	132*	132*
E2	30mm	15mm	Pb - Hw	PE foam backing	132*	132*	132*
F2	50mm	25mm	Pb - Hw	PE foam backing	132*	132*	132*

Pb - Plasterboard
Sw - Softwood
Hw - Hardwood
*Test was discontinued after a period of 132 minutes without a failure being observed.

Summary of report No.: FPA 104950 r0

A range of eighteen rockwool FIREPRO AIS Fire Resistance Sealant linear joint seals, mounted into apertures formed within a 100 mm low density rigid wall construction.

Horizontally orientated seals within a rigid wall

Specimen	Seal width	Seal depth	Substrate	Installation side	Backing material	Integrity (minutes)		Insulation (minutes)
						Cotton Pad	Sustained Flaming	
A	30mm	15mm	AAC	Exposed Face	PE foam Backer	239	258*	42
B	30mm	15mm	AAC	Unexposed Face	PE foam Backer	258*	166	71
C	30mm	15mm	AAC	Both faces	PE foam Backer	258*	258*	234

AAC – Low density masonry
 *Test was discontinued after a period of 258 minutes without a failure being observed.

Vertically orientated seals within a rigid wall

Specimen	Seal width	Seal depth	Substrate	Installation side	Backing material	Integrity (minutes)		Insulation (minutes)
						Cotton Pad	Sustained Flaming	
D	50mm	15mm	AAC-SW	Both faces	PE foam Backer	204	204	204
E	50mm	25mm	AAC	Exposed Face	RWA45	258*	258*	148
F	50mm	25mm	AAC	Unexposed Face	RWA45	258*	258*	257
G	50mm	25mm	AAC-SW	Both faces	PE foam backer	207	207	206
H	30mm	15mm	AAC-SW	Both faces	PE foam backer	173	173	148
I	50mm	25mm	Steel-Steel	Both faces	RWA45	258*	258*	129
J	50mm	25mm	AAC-Steel	Both faces	RWA45	258*	258*	111

K	30mm	15mm	AAC-Steel	Both faces	RWA45	258*	258*	99
L	50mm	25mm	AAC	Both faces	RWA45	258*	258*	258*
M	50mm	25mm	AAC	Both faces	PE foam backing	258*	258*	258*
N	30mm	15mm	AAC	Both faces	PE foam backing	258*	258*	258*
O	50mm	25mm	AAC	Exposed face	PE foam backing	258*	236	236
P	50mm	25mm	AAC	Unexposed face	PE foam backing	258*	255	182
Q	30mm	15mm	AAC	Exposed face	PE foam backing	258*	258*	72
R	30mm	15mm	AAC	Unexposed face	PE foam backing	258*	220	74

AAC – Low density masonry

SW – Softwood timber

Steel – Min. 2mm thick

*Test was discontinued after a period of 258 minutes without a failure being observed.

Summary of report No.: FPA 105764 r0

A range of twelve rockwool FIREPRO AIS Fire Resistance Sealant linear joint seals, mounted into apertures formed within a 75 mm thick EI 30 standard flexible wall construction. All joints were sealed on each face in a symmetrical configuration. The joint configurations followed the rules given in National Annex NA of the standard.

Vertically orientated seals within a flexible wall

Specimen	Seal width	Seal depth	Substrate	Backing material	Integrity (minutes)		Insulation (minutes)
					Cotton Pad	Sustained Flaming	
A1	30mm	15mm	Pb - Pb	PE foam backing	68*	68*	68*
B1	50mm	25mm	Pb - Pb	PE foam backing	68*	68*	68*
C1	30mm	15mm	Pb - Sw	PE foam backing	68*	68*	68*
D1	50mm	25mm	Pb - Sw	PE foam backing	68*	68*	68*
E1	30mm	15mm	Pb - Hw	PE foam backing	68*	68*	68*
F1	50mm	25mm	Pb - Hw	PE foam backing	68*	68*	68*

Pb - Plasterboard
Sw - Softwood
Hw - Hardwood
*Test was discontinued after a period of 68 minutes without a failure being observed.

Horizontally orientated seals within a flexible wall

Specimen	Seal width	Seal depth	Substrate	Backing material	Integrity (minutes)		Insulation (minutes)
					Cotton Pad	Sustained Flaming	
A2	30mm	15mm	Pb - Pb	PE foam backing	68*	68*	68*
B2	50mm	25mm	Pb - Pb	PE foam backing	68*	68*	68*
C2	30mm	15mm	Pb - Sw	PE foam backing	68*	68*	68*
D2	50mm	25mm	Pb - Sw	PE foam backing	68*	68*	68*
E2	30mm	15mm	Pb - Hw	PE foam backing	68*	68*	68*
F2	50mm	25mm	Pb - Hw	PE foam backing	68*	68*	61

Pb - Plasterboard
Sw - Softwood
Hw - Hardwood
*Test was discontinued after a period of 68 minutes without a failure being observed.

Summary of report No.: FPA 106130 r0

A range of four FIREPRO AIS Fire Resistance Sealant linear joint seals, mounted into apertures formed within a 150 mm thick rigid floor construction. All joints were sealed on the top face.

Specimen	Seal width	Seal depth	Substrate	Backing material	Integrity (minutes)		Insulation (minutes)
					Cotton Pad	Sustained Flaming	
A	30mm	15mm	AAC	PE foam backing	240*	240*	40
B	50mm	25mm	AAC	PE foam backing	240*	240*	82
C	30mm	15mm	AAC - Steel	PE foam backing	133	134#	36
D	50mm	25mm	AAC - Steel	PE foam backing	135	140#	60

Steel – Min. 2mm thick

*Test was discontinued after a period of 240 minutes without a failure being observed.

#Test specimen was blanked off to continue the test

Summary of report No.: 551825 A/R Iss1

A range of four FIREPRO AIS linear joint seals, mounted into apertures formed within a 100 mm thick EI 90 standard flexible wall construction. All joints were sealed each face in a symmetrical configuration.

Vertically orientated seals within a flexible wall

Specimen	Seal width	Seal depth	Substrate	Backing material	Integrity (minutes)		Insulation (minutes)
					Cotton Pad	Sustained Flaming	
A	30mm	15mm	AAC - Pb	10 mm PE foam backing + 50 mm steel stud	132*	132*	132*
B	30mm	25mm	AAC - Pb	50 mm steel stud	132*	132*	132*
D	30mm	12.5mm	AAC - Pb	75 mm RWA45	132*	132*	132*

Pb - Plasterboard

*Test was discontinued after a period of 132 minutes without a failure being observed.

Horizontally orientated seals within a flexible wall

Specimen	Seal width	Seal depth	Substrate	Backing material	Integrity (minutes)		Insulation (minutes)
					Cotton Pad	Sustained Flaming	
C	30mm	25mm	AAC - Pb	50 mm steel stud	132*	132*	132*
Pb – Plasterboard * Test was discontinued after a period of 132 minutes without a failure being observed.							

4. Classification and field of application

4.1 Reference of classification

This classification has been carried out in accordance with Clause 7 of EN 13501-2:2023.

4.2 Classification

The element, FirePro® AIS Fire Resistance Sealant is classified according to the following combinations of performance parameters and classes as appropriate.

R	E	I	W		t	t	-	M	S	-	C	IncSlow	sn	ef	r
---	---	---	---	--	---	---	---	---	---	---	---	---------	----	----	---

4.3 Supporting substrate types

Substrate type	Minimum specification
Single skin flexible walls	The flexible wall construction must be classified in accordance with EN 13501-2 for the required fire resistance period and must have a minimum thickness of 75 mm. The flexible wall construction comprise steel or timber studs lined on both faces with min 1 Layer of minimum 12,5 mm thick boards. For timber stud walls there must be a minimum distance of 100 mm of the seal to any stud. The cavity between stud and seal must be closed with an insulation of Class A1 (in accordance with EN 13501-1) for at least 100 mm distance.
Double skin flexible walls	The flexible wall construction must be classified in accordance with EN 13501-2 for the required fire resistance period and must have a minimum thickness of 100 mm. The flexible wall construction comprise steel or timber studs lined on both faces with min 2 Layer of minimum 12,5 mm thick boards. For timber stud walls there must be a minimum distance of 100 mm of the seal to any stud. The cavity between stud and seal must be closed with an insulation of Class A1 (in accordance with EN 13501-1) for at least 100 mm distance.
Rigid walls	The rigid wall must have a minimum thickness of 100 mm and comprise aerated concrete, concrete or masonry, with a minimum density of 650 kg/m ³ . Where the joint aperture incorporates a steel element (facing/lining) then the minimum allowable steel thickness shall be 2 mm.
Rigid floors	The rigid wall must have a minimum thickness of 150 mm and comprise aerated concrete, concrete or masonry, with a minimum density of 650 kg/m ³ . Where the joint aperture incorporates a steel element (facing/lining) then the minimum allowable steel thickness shall be 2 mm.

4.4 Product Installation

For wall applications then joints shall be sealed symmetrically either side of the wall (unless otherwise stated). Floor construction joints shall be sealed from the top side only (single seal).

The FirePro® AIS Fire Resistance Sealant shall be installed in line with the details given in the latest revision of Classification report 4791353094.1-01.

4.5 Classified performances

4.5.1 Rigid wall $\geq 100\text{mm}$

4.5.1.1 Rigid wall with single sided vertical seals

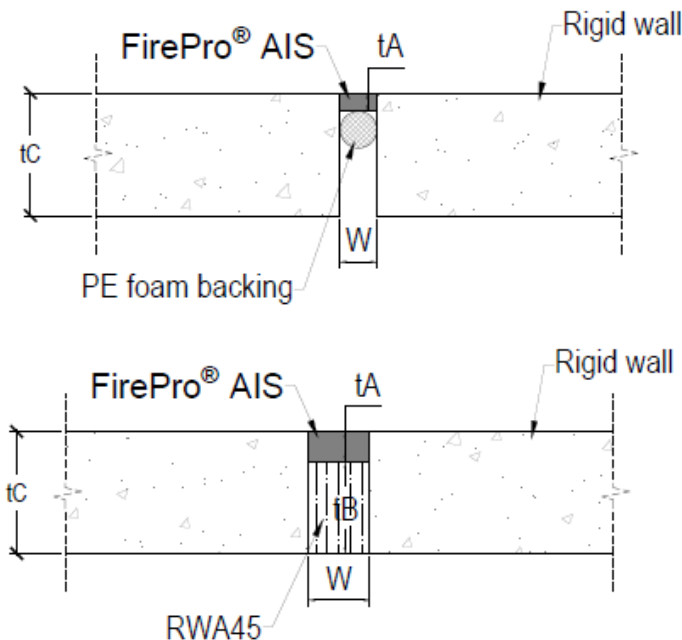
					<p>W = Joint width tA = Seal thickness tB = Stone mineral wool backer thickness tC = $\geq 100\text{mm}$</p> <p>Movement $\leq \pm 7.5\%$ (non-movement joints)</p> <p>*Stone Mineral Wool min 45 kg/m^3</p>
Substrate	Test orientation (Exp./Unexp. Face)	Joint width (W) (mm)	Seal Depth (tA) (mm)	Backing (tB) (mm)	Classification
AAC-AAC	Exposed	30	15	PE foam backing	EI 60-V-X-F-W 05 to 30 E 180-V-X-F-W 05 to 30
AAC-AAC	Unexposed	30	15	PE foam backing	EI 60-V-X-F-W 05 to 30 E 180-V-X-F-W 05 to 30
AAC-AAC	Exposed	50	25	PE foam backing	EI 180-V-X-F-W 05 to 50
AAC-AAC	Unexposed	50	25	PE foam backing	EI 180-V-X-F-W 05 to 50
AAC-AAC	Exposed	50	25	RWA45* (tB) = 75	EI 120-V-X-F-W 05 to 50 E 240-V-X-F-W 05 to 50
AAC-AAC	Unexposed	50	25	RWA45* (tB) = 75	EI 120-V-X-F-W 05 to 50 E 240-V-X-F-W 05 to 50

4.5.1.2 Rigid wall with single sided horizontal seals

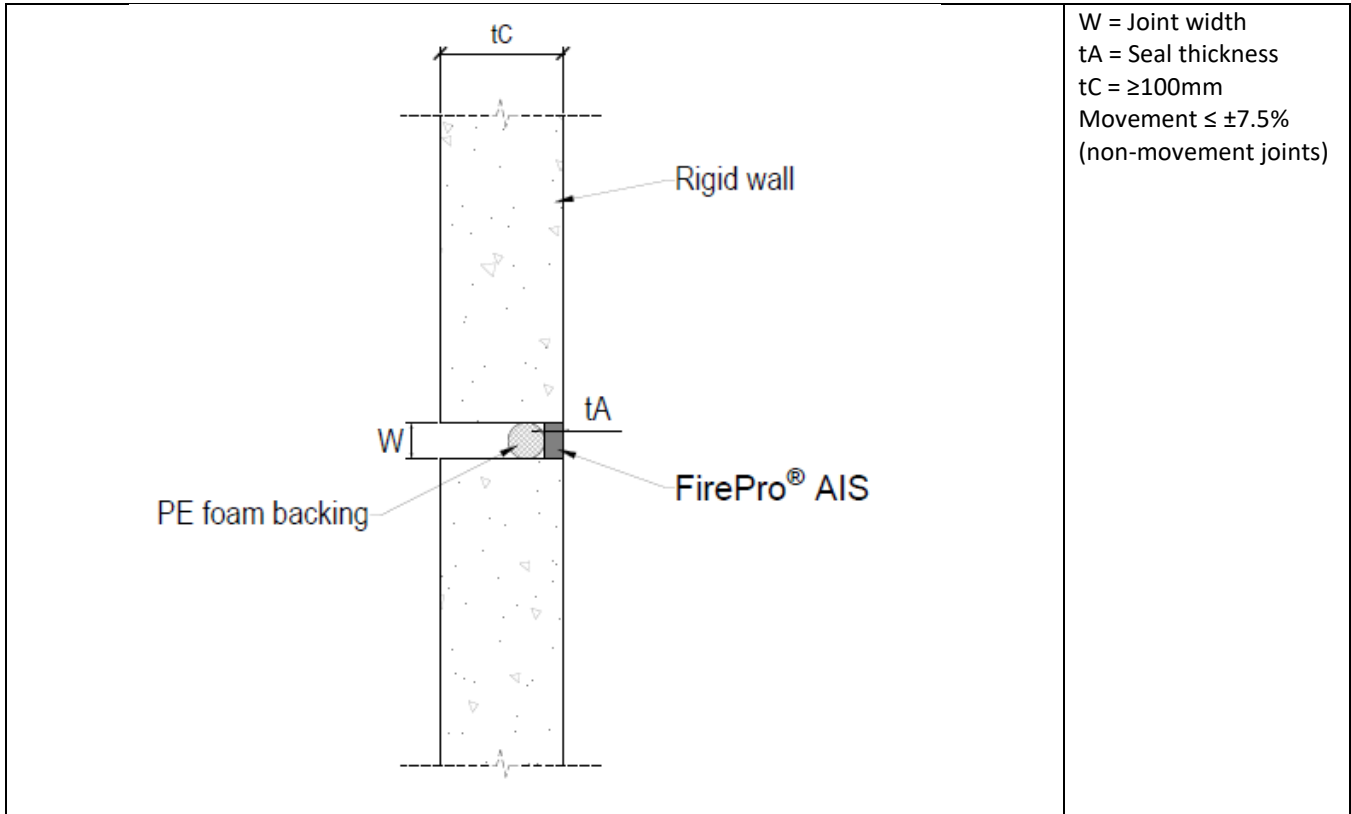

Substrate	Test orientation (Exp./Unexp. Face)	Joint width (W) (mm)	Seal Depth (tA) (mm)	Backing material	Classification
AAC-AAC	Exposed	30	15	PE foam backing	EI 30-T-X-F-W 05 to 30 E 120-T-X-F-W 05 to 30
AAC-AAC	Unexposed	30	15	PE foam backing	EI 30-T-X-F-W 05 to 30 E 120-T-X-F-W 05 to 30

4.5.1.3 Rigid wall with symmetrical horizontal seals

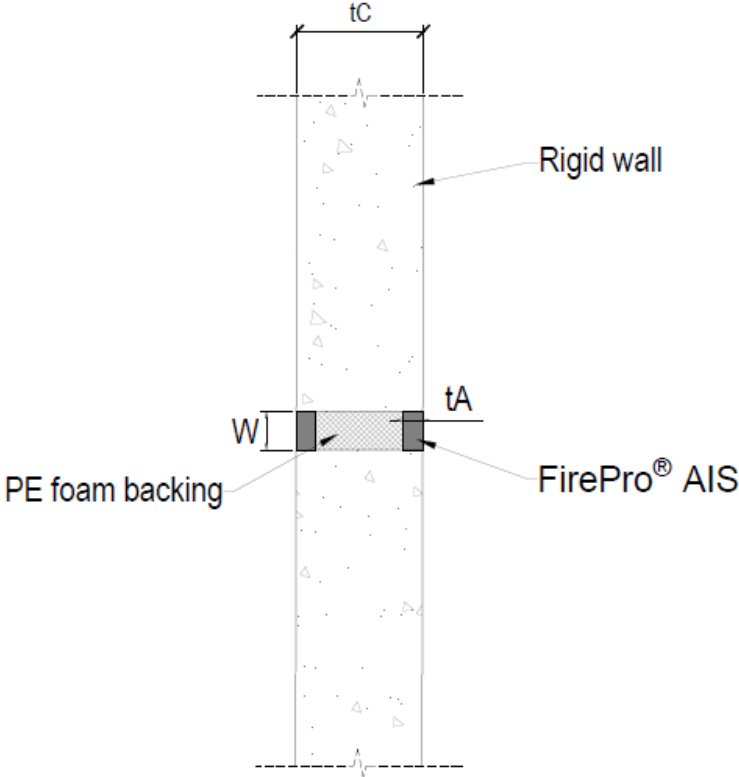
				<p>W= Joint width tA= Seal thickness tC = ≥100mm</p> <p>Movement ≤ ±7.5% (non-movement joints)</p>
Substrate	Joint width (W) (mm)	Seal Depth (tA) (mm)	Backing material	Classification
AAC-AAC	30	15	PE foam backing	EI 180-T-X-F-W 05 to 30 E 240-T-X-F-W 05 to 30

4.5.1.4 Rigid wall with symmetrical vertical seals

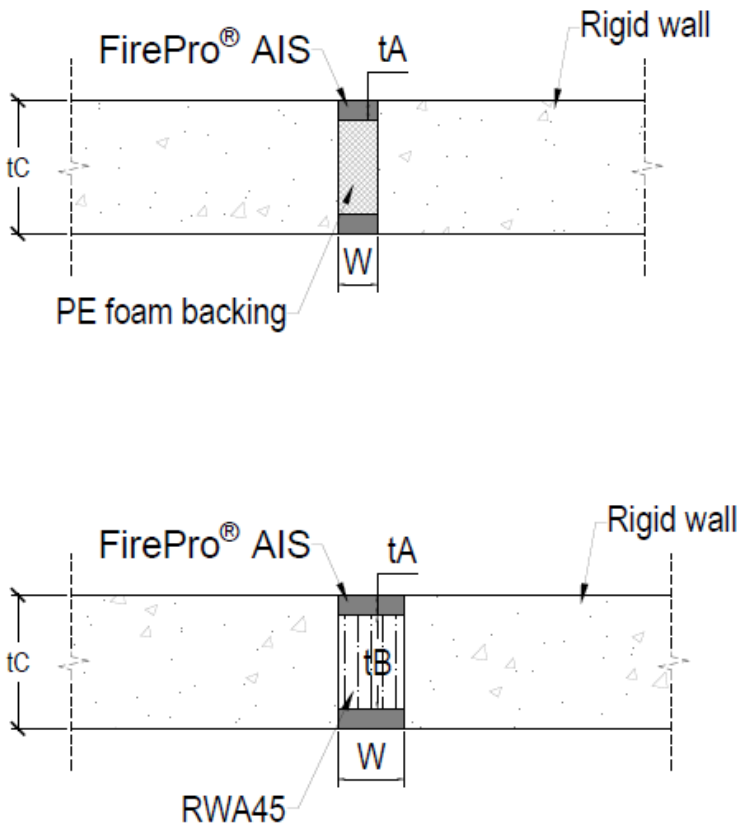
				<p>W = Joint width tA = Seal thickness tB = Stone mineral wool backer thickness tC = ≥100mm</p> <p>Movement ≤ ±7.5% (non-movement joints)</p> <p>*Stone Mineral Wool min 45 kg/m³</p>
Substrate	Joint width (W) (mm)	Seal Depth (tA) (mm)	Backing (tB) (mm)	Classification
AAC-AAC	30	15	PE foam backing	EI 240-V-X-F-W 05 to 30
AAC-AAC	50	25	PE foam backing	EI 240-V-X-F-W 05 to 50
AAC-AAC	50	25	RWA45* (tB) = 50	EI 240-V-X-F-W 05 to 50

4.5.1.5 Rigid wall with softwood timber facings

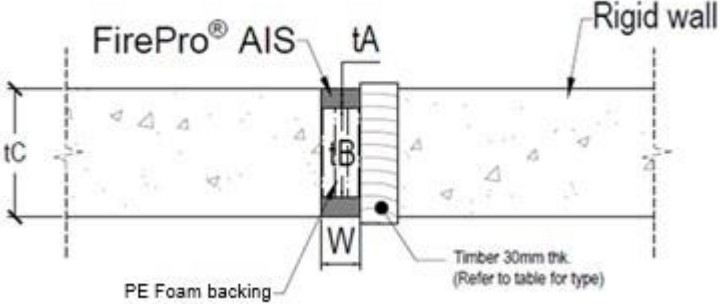
				<p>W = Joint width tA = Seal thickness tC = ≥100mm</p> <p>Movement ≤ ±7.5% (non-movement joints)</p>
Substrate	Joint width (W) (mm)	Seal Depth (tA) (mm)	Backing material	Classification
AAC-Softwood	30	15	PE foam backing	EI 120-V-X-F-W 05 to 30
AAC-Softwood	50	25	PE foam backing	EI 180-V-X-F-W 05 to 50

4.5.1.6 Rigid wall with steel facings

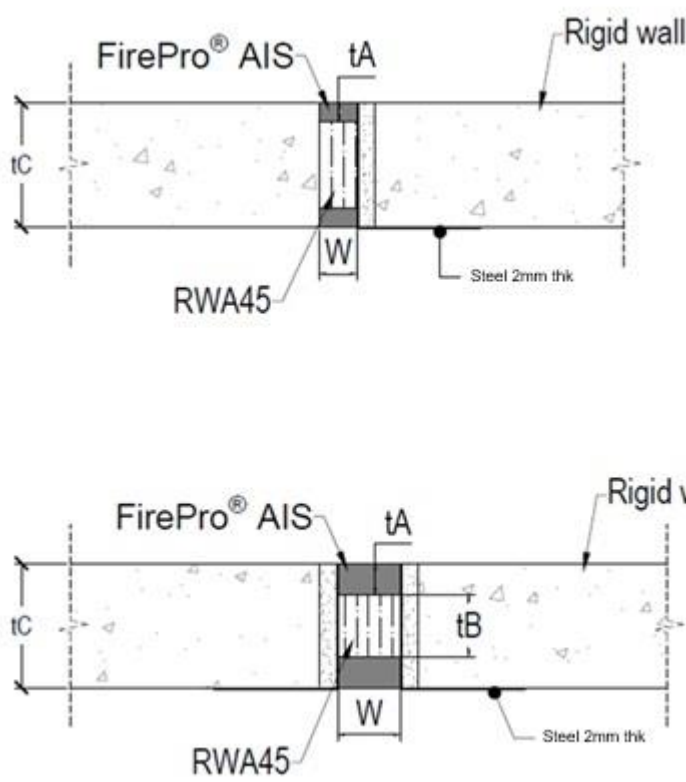
				<p>W = Joint width tA = Seal thickness tB = Stone mineral wool backer thickness tC = $\geq 100\text{mm}$</p> <p>Movement $\leq \pm 7.5\%$ (non-movement joints)</p> <p>*Stone Mineral Wool min 45 kg/m³</p>
Substrate	Joint width (W) (mm)	Seal Depth (tA) (mm)	Backing (tB) (mm)	Classification
AAC-Steel	30	15	RWA45* (tB) = 70	EI 90-V-X-F-W 05 to 30 E 240-V-X-F-W 05 to 30
AAC-Steel	50	25	RWA45* (tB) = 50	EI 90-V-X-F-W 05 to 50 E 240-V-X-F-W 05 to 50
Steel-Steel	50	25	RWA45* (tB) = 50	EI 120-V-X-F-W 05 to 50 E 240-V-X-F-W 05 to 50

4.5.2 Rigid floor construction

4.5.2.1 Rigid floor construction unlined

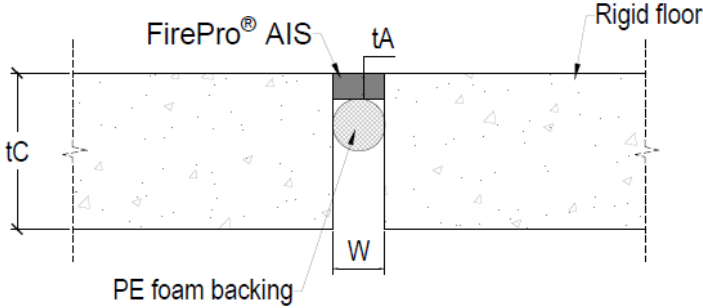
				<p>W = Joint width tA = Seal thickness tC = ≥150 mm rigid floor</p> <p>Movement ≤ ±7.5% (non-movement joints)</p> <p>≥650 kg/m³ min floor density</p>
Substrate	Joint width (mm)	Depth (tA) (mm)	Backing material	Classification
AAC – AAC	30	15	PE foam backing	EI 30-H-X-F-W 05 to 30 E 240-H-X-F-W 05 to 30
AAC – AAC	50	25	PE foam backing	EI 60-H-X-F-W 05 to 50 E 240-H-X-F-W 05 to 50

4.5.2.2 Rigid floor construction with steel facings

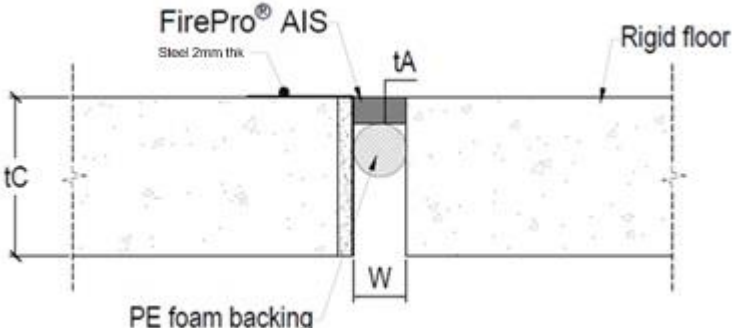
				<p>W = Joint width tA = Seal thickness tC = ≥150 mm rigid floor</p> <p>The steel facing shall have a minimum thickness of 2 mm</p> <p>Movement ≤ ±7.5% (non-movement joints)</p> <p>≥650 kg/m³ min floor density</p>
Substrate	Joint width (mm)	Depth (tA) (mm)	Backing material	Classification
AAC – Steel	30	15	PE foam backing	EI 30-H-X-F-W 05 to 30 E 120-H-X-F-W 05 to 30
AAC – Steel	50	25	PE foam backing	EI 60-H-X-F-W 05 to 50 E 120-H-X-F-W 05 to 50

4.5.3 Flexible wall construction $\geq 100\text{mm}$

4.5.3.1 Double skin flexible walls with vertically orientated seals

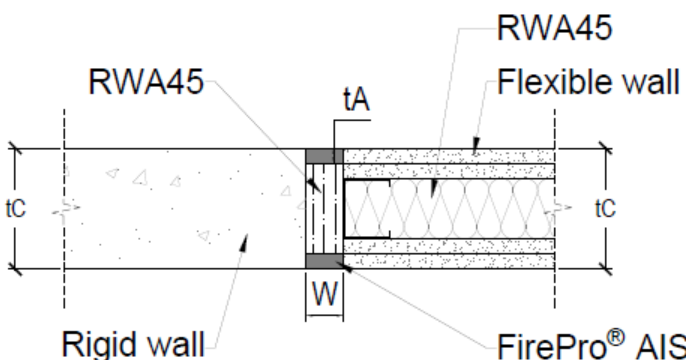
				<p>W = Joint width tA = Seal thickness tB = Stone mineral wool backer thickness tC = $\geq 100\text{mm}$</p> <p>Movement $\leq \pm 7.5\%$ (non-movement joints)</p> <p>*Stone Mineral Wool min 45 kg/m^3</p>
Substrate	Joint width (W) (mm)	Seal Depth (tA) (mm)	Backing material	Classification
AAC - Plasterboard	30	12.5	RWA45* (tB) = 75mm	EI 120-V-X-F-W 05 to 30

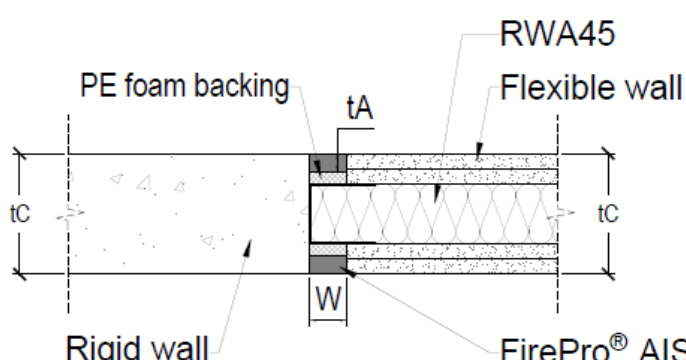
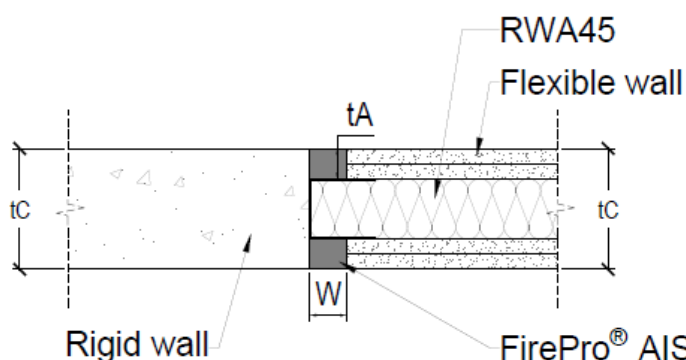
				<p>W = Joint width tA = Seal thickness tC = ≥100mm</p> <p>Movement ≤ ±7.5% (non-movement joints)</p>
				
Substrate	Joint width (W) (mm)	Seal Depth (tA) (mm)	Backing material	Classification
AAC - Plasterboard	30	15	10 mm PE foam backing + 50 mm steel stud	EI 120-V-X-F-W 05 to 30
AAC - Plasterboard	30	25	50 mm steel stud	EI 120-V-X-F-W 05 to 30

Double skin flexible walls with Horizontally orientated seals

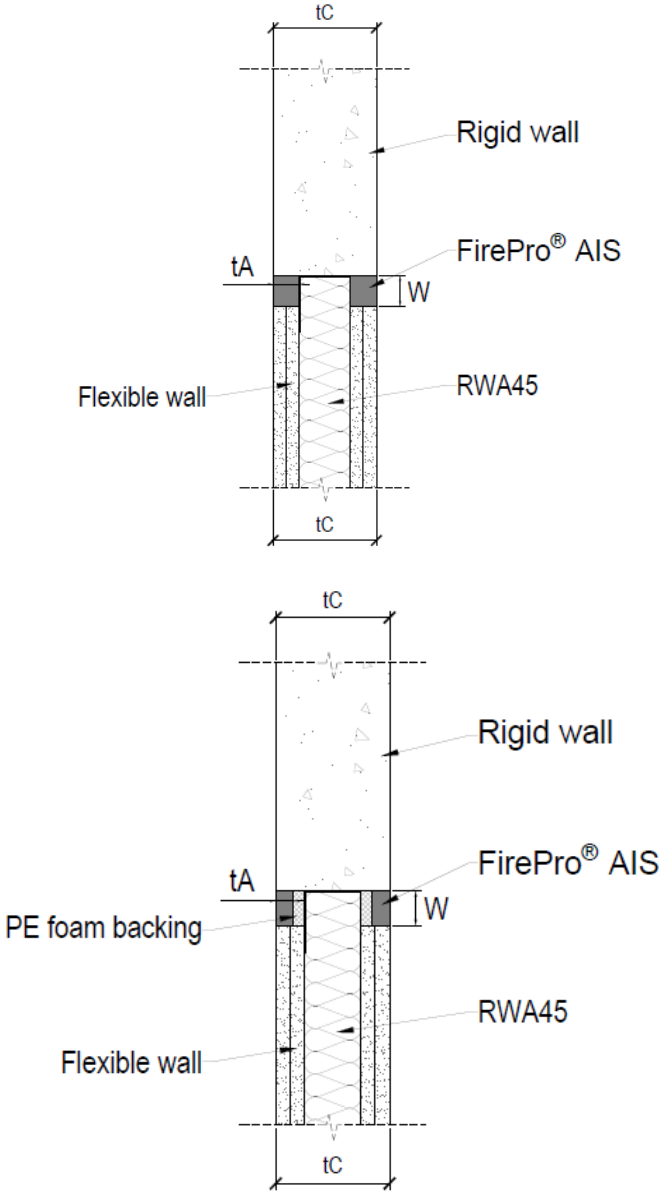
				<p>W = Joint width tA = Seal thickness tC = ≥ 100mm</p> <p>Movement $\leq \pm 7.5\%$ (non-movement joints)</p>
Substrate	Joint width (W) (mm)	Seal Depth (tA) (mm)	Backing material	Classification
AAC - Plasterboard	30	25	50 mm steel stud	EI 120-T-X-F-W 05 to 30

5. Limitations

This classification report does not represent type approval or certification of the product.

6. Signatories

Report by:

A handwritten signature in blue ink, appearing to read 'Andres Jesus Mena Gallego'.

Andres Jesus Mena Gallego
Associate Project Engineer
Built Environment

Reviewed by:

A handwritten signature in blue ink, appearing to read 'Chris Sweeney'.

Chris Sweeney
Senior Project Engineer
Built Environment

For and on behalf of UL International (UK) Ltd.

Annex A - Informative

Testing was additionally conducted following the National (informative) Annex corresponding to BS EN 13501-2: 2023 and thus are not suitable for formal classification according to EN 13501-2: 2023, however for the purpose of use in within the UK, the following classifications may be interpreted:

Flexible walls – Single skin flexible walls $\geq 75\text{mm}$

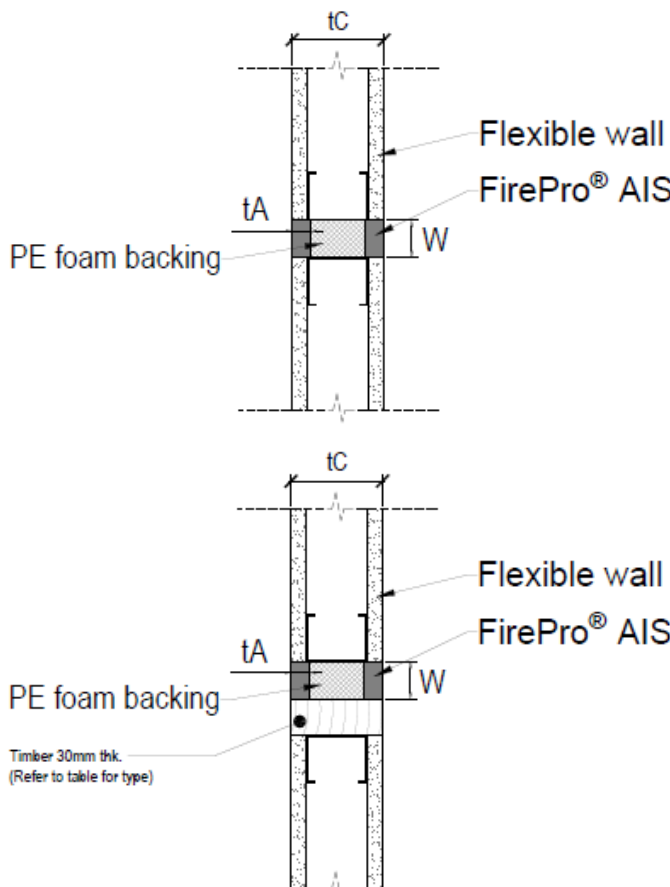
				<p>W = Joint width tA = Seal thickness tC = $\geq 75\text{mm}$</p> <p>Movement $\leq \pm 7.5\%$ (non-movement joints)</p>
Substrate	Joint width (W) (mm)	Seal Depth (tA) (mm)	Backing material	Classification
Plasterboard - Plasterboard	30	15	PE foam backing	EI 60-V-X-F-W 05 to 30
Plasterboard - Plasterboard	30	15	PE foam backing	EI 60-T-X-F-W 05 to 30
Plasterboard - Plasterboard	50	25	PE foam backing	EI 60-V-X-F-W 05 to 50
Plasterboard - Plasterboard	50	25	PE foam backing	EI 60-T-X-F-W 05 to 50
Plasterboard – Softwood timber	30	15	PE foam backing	EI 60-V-X-F-W 05 to 30

Substrate	Joint width (W) (mm)	Seal Depth (tA) (mm)	Backing material	Classification
Plasterboard – Softwood timber	30	15	PE foam backing	EI 60-T-X-F-W 05 to 30
Plasterboard – Softwood timber	50	25	PE foam backing	EI 60-V-X-F-W 05 to 50
Plasterboard – Softwood timber	50	25	PE foam backing	EI 60-T-X-F-W 05 to 50
Plasterboard – Hardwood timber	30	15	PE foam backing	EI 60-V-X-F-W 05 to 30
Plasterboard – Hardwood timber	30	15	PE foam backing	EI 60-T-X-F-W 05 to 30
Plasterboard – Hardwood timber	50	25	PE foam backing	EI 60-V-X-F-W 05 to 50
Plasterboard – Hardwood timber	50	25	PE foam backing	EI 60-T-X-F-W 05 to 50

Flexible walls – Double skin flexible walls $\geq 100\text{mm}$

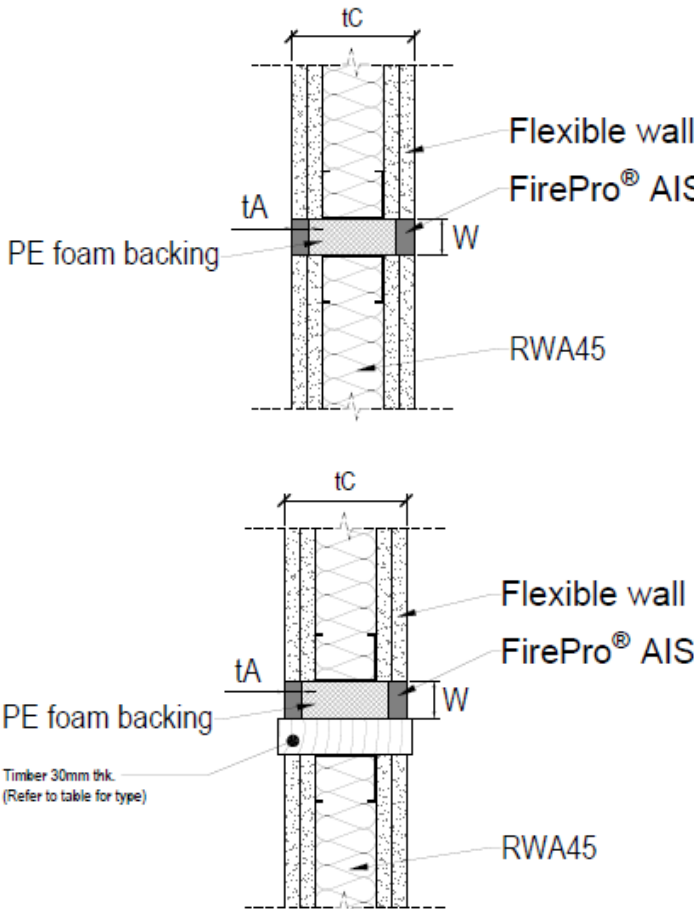
				<p>W= Joint width tA= Seal thickness tC= $\geq 100\text{mm}$</p> <p>Movement $\leq \pm 7.5\%$ (non-movement joints)</p>
Substrate	Joint width (W) (mm)	Seal Depth (tA) (mm)	Backing material	Classification
Plasterboard - Plasterboard	30	15	PU foam backing	EI 120-V-X-F-W 05 to 30
Plasterboard - Plasterboard	30	15	PU foam backing	EI 120-T-X-F-W 05 to 30
Plasterboard - Plasterboard	50	25	PU foam backing	EI 120-V-X-F-W 05 to 50
Plasterboard - Plasterboard	50	25	PU foam backing	EI 120-T-X-F-W 05 to 50
Plasterboard – Softwood timber	30	15	PU foam backing	EI 120-V-X-F-W 05 to 30
Plasterboard – Softwood timber	30	15	PU foam backing	EI 120-T-X-F-W 05 to 30
Plasterboard – Softwood timber	50	25	PU foam backing	EI 120-V-X-F-W 05 to 50

Plasterboard – Softwood timber	50	25	PE foam backing	EI 120-T-X-F-W 05 to 50
Plasterboard – Hardwood timber	30	15	PE foam backing	EI 120-V-X-F-W 05 to 30
Plasterboard – Hardwood timber	30	15	PE foam backing	EI 120-T-X-F-W 05 to 30
Plasterboard – Hardwood timber	50	25	PE foam backing	EI 120-V-X-F-W 05 to 50
Plasterboard – Hardwood timber	50	25	PE foam backing	EI 120-T-X-F-W 05 to 50